

Question block created by wizard

This exam contains 92 questions.

1. Newton's first law states:
 - a. When a body is acted upon by an external force, the rate change of momentum is proportional to the force and takes place in the direction of the force.
 - b. To every action there is an opposite and equal reaction.
 - c. A body will remain at rest or will continue in uniform motion in a straight line unless acted upon by force.

2. Positive and negative signs of work indicate whether the object exerting the:
 - a. heat required to transferring energy to some other object, or receiving it.
 - b. work loss through heat expanded.
 - c. force is transferring energy to some other object, or receiving it.

3. Which engine has a better stall characteristic?
 - a. Both answers are correct.
 - b. Multi spool axial flow engine.
 - c. Single spool axial flow engine.

4. The difference in operation between a propeller and a jet engine can be summarized as follows:
 - a. A propeller accelerates a large quantity of air rearwards at a high rate. A jet engine accelerates a small quantity of air rearwards at a low rate.
 - b. A propeller accelerates a large quantity of air rearwards at a low rate. A jet engine accelerates a small quantity of air rearwards at a high rate.
 - c. Propeller is pulling while a jet engine is only compressing air.

5. In what unit is the engine output power of a turbojet normally measured?
 - a. Turbopower.
 - b. Thrust lbs or kg.
 - c. Jet thrust.

6. Thrust of a gasturbine engine comes from....
 - a. the acceleration of the air and fuel molecules.
 - b. the pressure of the exhaust against the atmosphere.
 - c. the enormous suction at the engine inlet.

- 7.** The engine data and engine assembly identification plates are attached to the engine.

What data do these plates provide?

- a. Engine specification as designed by the manufacturer for the aircraft configuration.
- b. Aircraft specification as designed by the manufacturer for the engine to be installed.
- c. Engine specification as designed by the manufacturer.

- 8.** The bypass ratio of a modern turbofan is....

- a. around 2 : 1.
- b. around 5 : 1.
- c. around 8 : 1.

- 9.** Air velocity at the inlet of the low pressure compressor must be around....

- a. Mach 0.1
- b. Mach 0.5
- c. Mach 0.9

- 10.** Thrust stays constant until flat rate temperature point is reached.

What happens next?

- a. Thrust begins to increase due to higher RPM and thinner air pressure.
- b. Thrust begins to increase because of lower temperature.
- c. Thrust begins to decrease.

11. During flight, the distribution of static pressure in and around the engine is as follows:



- a. A: High pressure, B: Low pressure, C: High pressure
- b. A: Low Pressure, B: High Pressure, C: Low Pressure
- c. A: Low pressure, B: Low pressure, C: High pressure

12. What shape does a bifurcated intake have?

- a. Divergent from front to rear.
- b. Convergent from front to rear.
- c. First divergent, then convergent towards the rear.

13. What is the most effective intake shape for supersonic speeds?

- a. Divergent - convergent duct.
- b. Convergent - divergent duct.
- c. Straight duct.

14. On an engine with hot air anti-icing, where does the air come from?

- a. From the engine itself.
- b. From the aircraft air system.
- c. From the opposite engine.

15. How is the hot air anti-ice system activated?

- a. Automatically when ice is detected
- b. The system is always on and can not be switched off
- c. Manually from the flightdeck

16. Which types of compressors are mostly used in turbofan and turbojet engines?

- a. Combination of both axial flow and centrifugal compressors.
- b. Centrifugal compressors.
- c. Axial flow compressors.

17. What kind of fixing method do you see in the picture?



- a. Dove tail type
- b. Pinned type.
- c. Fir tree root type.

18. Fan blades can be removed and replaced, however the replaced blade must be of the....

- a. same moment and weight class.
- b. production batch.
- c. same color code.

19. What is an advantage of the Wide Chord Fan Blade Technology?

- a. Increase weight.
- b. Much longer life of operation.
- c. The number of blades can be reduced.

20. What can cause a compressor stall or surge?

- a. A rapid throttle movement.
- b. A low take off speed.
- c. A high speed landing.

21. Compressor bleed control valves are normally spring loaded to the...

- a. closed position.
- b. mid-range position.
- c. open position.

22. The term "overall pressure ratio" is defined as the ratio of the...

- a. pressure at the front and rear of the compressor of a gas turbine engine.
- b. stagnation pressure due to the rotoring speed of the shafts against the compressor inner wall.
- c. stagnation pressure at the combustion chamber.

23. The compressor outlet delivers compressed air, to a component in front of the combustion section.

How do you call this?

- a. Nozzle section.
- b. The exhaust section of the compressor.
- c. Diffuser.

24. What kind of combustion chamber is shown in the picture?



- a. Annular combustion chamber.
- b. Turbo-annular combustion chamber.
- c. Multiple combustion chamber.

25. On multi spool engines the overall pressure ratio is....

- a. the square of all the individual compressor stages.
- b. the sum of all individual compressor stages.
- c. the multiplication of all the individual compressor stages.

26. The nozzle area in an impuls type turbine is....

- a. divergent.
- b. convergent.
- c. constant flow.

27. What is the most common method of attaching turbine blades to the disk?

- a. Dove tail
- b. Fir-tree
- c. Radial slots

28. The end of which creep phase determines the blade safe life limit?

- a. Secondary.
- b. Tertiary.
- c. Primary.

29. What will happen to the turbine blade when it reaches the tertiary creep stage?

The blade will...

- a. be under a constant rate of extension.
- b. become weak.
- c. eventually break away.

30. What exhaust nozzle style is described?

"This duct converts much of the heat and pressure energy in the gases into kinetic energy. The gases thus leave the nozzle at high velocity."

- a. Convergent nozzle.
- b. Bellmouth nozzle.
- c. Subsonic divergent nozzle.

- 31.** The nozzle is fitted at the final end of the exhaust duct and for subsonic aircraft it will be convergent in shape.

That is why the velocity of the turbine discharge gases is relatively...

- a. cool but it is decreased before they are discharged.
- b. high but it is decreased before they are discharged.
- c. low but it is increased before they are discharged.

- 32.** Blocker door type (cold stream) are mostly used on....

- a. supersonic aircraft.
- b. high by-pass engines.
- c. thrust vectoring nozzles systems.

- 33.** What are the most common used oil seals?

- a. Labyrinth, thread (helical type) and carbon seals.
- b. Thread (helical type), carbon seals and scrappers.
- c. Labyrinth, scrapper and carbon seals.

- 34.** What is the advantage to use hydraulic bearings in newer engines?

- a. Reduces vibrations transmitted to the engine.
- b. Increases the lifetime of the bearing.
- c. Reduces vibrations transmitted to the engine cooling system.

- 35.** The main bearings have the critical function of supporting the main engine rotor.

The number of bearings necessary for proper engine support is, for the most part, determined by...

- a. length and weight of the engine.
- b. thrust and weight of the engine.
- c. life expectance of the engine between overhaul.

- 36.** What is the most widely used fuel for aircraft with jet engines?

- a. Jet A / A1
- b. JP 8
- c. Jet B

- 37.** What is a difference between Jet A and Jet A-1 fuel?
- Sulfur mass.
 - Freezing point.
 - Fuel density.
- 38.** What is the advantage of jet fuel A1, compared to jet fuel A?
- Lower freezing point.
 - Higher burning rate.
 - Higher freezing point.
- 39.** Increasing the flashpoint would reduce the...
- volatile and low-boiling components of the fuel.
 - weight of the fuel.
 - quantity of the fuel.
- 40.** The oil level is normally checked between 5 minutes and 30 minutes after the engine has been shut down. For safety, do not check the oil for at least five minutes after shutdown.
- Why is it required to a certain length of time?
- For all the oil to drain back to the gear box.
 - This allows the tank pressure to deplete and limits the amount of oil drainage to the gearbox.
 - So that all the oil loses its air through the breather and foaming of oil is reduced.
- 41.** The engine oil tank is a...
- unpressurized container.
 - reservoir for the engine oil system.
 - sump below the engine to return the oil by gravity.
- 42.** What is the function of the Fuel / Oil Heat Exchanger?
- Cooling of fuel.
 - Cooling of oil and heating of fuel.
 - Heating of oil.
- 43.** What component in the oil tank will separate the oil from the air?
- The pressure relief valve.

- b. A ball valve.
- c. The centrifugal breather.

44. The electronic control unit on a gas turbine is a...

- a. dual channel processor.
- b. 4-channel processor.
- c. single channel processor.

45. The thrust level request on a FADEC engine is transmitted through a....

- a. TLA resolver.
- b. push/pull control rod system.
- c. mechanical cable system.

46. When the fuel flow transmitter is not installed within 24 hours on the system...

- a. fill the transmitter with fuel and drain afterwards.
- b. fill the transmitter with engine oil and drain afterwards.
- c. it must be covered in a plastic bag.

47. What is the purpose of the L.P. pump?

- a. To ensure the engine will continue to run if the H.P. fuel pump fails.
- b. To ensure rapid acceleration when the throttle is opened.
- c. To prevent cavitation of the H.P. fuel pump.

48. The fuel manifold carries fuel to spray nozzles.

The spray nozzles spray fuel into the...

- a. diffuser case.
- b. first stage of the turbine vanes.
- c. combustion chamber.

49. The HP fuel pump receives its flow from the...

- a. fuel nozzles.
- b. low pressure system (low pressure pump).
- c. fuel tank booster pumps however only in takeoff.

- 50.** What is the purpose of the accessory cooling system?
- To avoid the engine oil temperature exceeds 580 °C.
 - Removes excessive heat from the engine and nacelle components.
 - Allowing engine components to heat up to operating temperature.
- 51.** What do large gas turbine engines usually use to prevent icing?
- Electrical heating in flight only.
 - Hot air from the turbine sections
 - Hot air from the compression section
- 52.** Compressor Stability Control permits compressor stability...
- only during high power settings
 - during cruise power only.
 - during starting and engine operation.
- 53.** What are the two main methods used for starting aircraft engines?
- Battery powered electrical starter and vacuum starter.
 - Manual crank starters and hydraulic motor driving a clutch system.
 - Electric starters and air starters.
- 54.** The starter motor is capable of cranking the engine to a speed slightly higher than....
- that at which sufficient gas flow is generated to enable the engine to accelerate under its own power.
 - idle speed.
 - that at which sufficient air flow is provided to have combustion.
- 55.** Give the best answer:
- When working on the ignition system....
- switch off and wait several minutes before removing components from the ignition system.
 - remove the ignition leads from the exciter box and than remove the ignitors.
 - switch off and start removing the components from the ignition system.
- 56.** The ignition system supplies electrical energy at high voltage to...
- start or sustain combustion of the fuel-air mixture in the engine.
 - rotate the gearbox which causes engine start.

- c. the turbine section for quick engine starting.

57. "Ignition system voltage is dangerously high. Ignition switch must be in off position before removal of any ignition component." This is a warning.

Why?

- a. The ignition box has to warm up because it extremely cold.
- b. Because it could result in severe injury to personnel
- c. Could cause early rotation of the starter.

58. The EGT Harness connects to a terminal block.

From the terminal block, the EGT signal is sent to a...

- a. resistor to decrease the actual temperature otherwise it can be too high.
- b. display.
- c. voltage generator, to increase the temperature.

59. On a modern turbofan engine, the engine pressure ratio (EPR) indicating system measures the pressure ratio across the...

- a. compressor including low pressure.
- b. only pressure outlet (exhaust).
- c. fan.

60. The oil pressure transmitter senses the difference between pressure pump delivery pressure and...

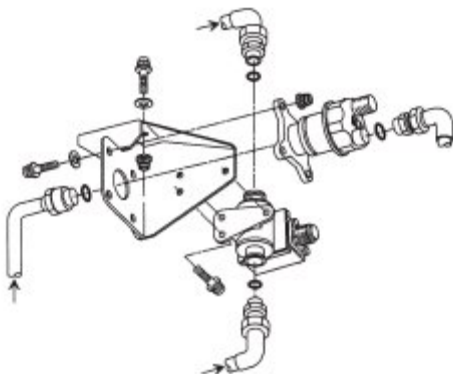

- a. the gear box pressure.
- b. the FCOC (Fuel Cooled Oil Cooler).
- c. the ISA parameters.

61. The engine tachometer N2 system senses engine speed.

It displays the speed on EICAS in....

- a. engine pounds of thrust.
- b. rpm (revolutions per minute).
- c. percent.

62. Engine torque is used to indicate...

- a. lateral twist on the engine mouths.
- b. the power that is developed by a turbo fan engine.
- c. the power that is developed by a turbo-propeller engine.

63. The greatest advantage of the water injection system is...

- a. the heating.
- b. cooling inlet air.
- c. the cooling of the turbine.

64. The mass flow rate of air through the engine is depending on the density of the air.

A higher mass flow rate results in...

- a. a greater thrust of the engine.
- b. a higher engine temperature.
- c. a lower thrust output.

65. Which system is normally used on turbo-jet engines to augment the thrust of the engine for short periods?

- a. Afterburner.
- b. In cruise.
- c. Pre-ignition.

66. The propeller is allowed to go to its feather position when the engine is shut down. What type of turbine is this?

- a. Axial flow turbine.
- b. Free turbine.
- c. Coupled turbine.

67. What is the advantage of a parallel spur gear train?

It is...

- a. mechanically simple and therefore relatively cheap to manufacture.
- b. mechanically simple but relatively expensive to manufacture.
- c. mechanically complex but relatively cheap to manufacture.

68. On a typical free turbine turboprop engine the propeller control lever is connected to the...

- a. propeller governor.
- b. constant speed fuel mixing unit.
- c. fuel control unit.

69. Overspeed is the condition in which the actual engine speed is higher than the desired engine speed set.

How is this prevented?

- a. Only by throttle being retarded.
- b. Centrifugal forces of the fan.
- c. By overspeed governor.

70. Drive shaft and flexible coupling, turbine helicopters make use of a short shaft system to deliver power to a:

- a. transmission.
- b. turbine.
- c. compressor.

71. The most commonly used turbo-shaft engines today are from the...

- a. single shaft type.
- b. free-turbine type.
- c. fixed-turbine type.

72. What is a turbo-shaft engine?

- a. A turbine that drives a high speed ultra high bypass compressor.
- b. Axial flow compressor with a propeller drive system, used in large commercial aircraft
- c. A gas turbine engine that delivers power through a rotating shaft.

- 73.** The parallel spur gear type and the epicyclic type describe...
- excitation gear systems.
 - reduction gear systems.
 - eccentric gear systems.
- 74.** The APU control unit (ECU) completely controls...
- automatic selection of air source, no pilot interface needed, including start.
 - start and acceleration.
 - start and acceleration including automatic selection of air.
- 75.** Reverse flow in an APU will...
- not cause a shutdown.
 - cause a protective shutdown.
 - be automatically corrected by the ECU.
- 76.** What type of compressor and combustion chamber is used in the power section of an APU?
- Axial flow compressor to save space and can combustion chamber.
 - Axial flow compressor to save space and annular combustion chamber.
 - Centrifugal compressor with a reverse flow annular combustion chamber.
- 77.** The igniter provides the spark to the...
- combustor chamber.
 - turbine on APU with a reverse flow combustion chamber.
 - fuel nozzle injector during all phases of APU operation.
- 78.** Powerplants are often divided into zones by fireproof bulkheads.
- Bulkheads are usually made of...
- aluminum alloy.
 - harden steel.
 - stainless steel, titanium.
- 79.** When you need no overhead crane or other external hoist devices to change an engine.
- This is a...
- Single hoist equipment.
 - Chain hoist equipment.

- c. Bootstrap equipment.

80. The pylon transmits engine loads to the wing through the...

- a. wing spars, front and rear.
- b. lower wing surface.
- c. forward bulkhead and aft mount bulkhead.

81. What causes the majority of outside noise in a high-bypass engine?

- a. HP fan.
- b. LP fan.
- c. Core Engine.

82. The fire extinguishing system protects those sections of the airplane...

- a. where a fire could initiate. Controls and system status indications are located in the cockpit.
- b. where a fire could initiate. Controls and system status indications related to the cabin are located in FWD Cabin Station. All other controls and systems are located in the cockpit.
- c. selected by each flight crew before departure.

83. Turbine case cooling is used to....

- a. improve service life of the high pressure compressor.
- b. reduce turbine rotor vane clearances and improve engine efficiency.
- c. improve gasturbine starting characteristics at high altitude.

84. Fire is one of the most dangerous threats to an aircraft.

How are the potential fire zones of all multi engine aircraft which are currently produced, protected?

- a. by fire funnels.
- b. by a fixed fire protection system.
- c. by a portable fire protection system.

85. Extinguishing agent is discharged through a...

- a. solid material that melts on heat contact.
- b. pipeline system
- c. solid state generator the a pipeline system is too heavy for large airplanes.

86. An "engine start without ignition" is indicated by...

- a. low RPM.
- b. no temperature indication.
- c. compressor stall.

87. What is the maximum power setting the pilot can use in an emergency situation?

- a. Maximum climb.
- b. Maximum continuous thrust.
- c. Maximum cruise.

88. Trend monitoring is a system of routine comparison of engine performance parameters with a base line of the same parameters.

How is this accomplished?

- a. Graphs or curves are used to show trends in changing conditions.
- b. Each Pilots log book entry is compared to the baseline.
- c. Via downloading the post flight report from the on-board maintenance system.

89. One procedure that has improved efficiency is the built-in provision for inspecting the inside of the engine without disassembling it.

This is performed by...

- a. borescope equipment.
- b. large access ports installed through each module of the engine.
- c. xray of the internal parts on a regular time frame.

90. Foreign object damage (FOD) comes from many sources.

What are the most common?

- a. Taxi ways.
- b. Ice / hail.
- c. Birds.

91. When performing a ground test on a turbine engine....

- a. tailwind is not permitted.
- b. a little tailwind is ok as long as it does not exceed 10 knots.
- c. the orientation of the aircraft relative to wind direction is not important.

92. When the fuel system is flushed for preservation, there has

- a. engine oil to be filled in the system.
- b. preservative oil to be filled in the system.
- c. clean fuel to be filled in the system.